

Dorgard

Technical specification sheet

Dorgard 1328-A01 (acoustic fire door retainer)

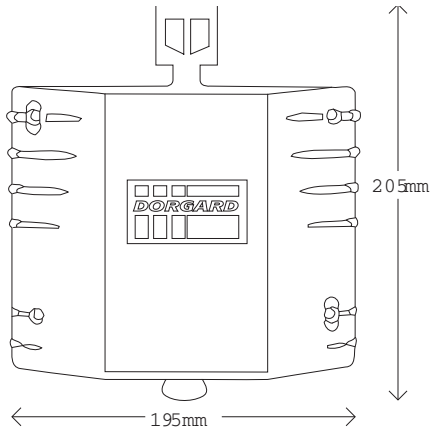

Dimensions and weight

- Overall height: 205mm
- Main casing height: 150mm
- Width: 195mm
- Depth: 45mm
- Packed kit weight: 950g
- Product only (including batteries): 700g

Material and operating specifications

- Casing: ABS
- Power: 2 x 1.5v C size alkaline batteries
(do not use rechargeable batteries)
- Expected battery life: 12 months
- Trigger: by alarms compliant with BS 5839-3

Dorgard 1328-A01 approvals and standards

- BS EN 1155: 1997 building hardware. Electrically powered hold-open devices for swing doors. (Manufacturer's classification number 357113).
- EN61000-6-1:2001 Electromagnetic compatibility (EMC). Generic standards. Immunity for residential, commercial and light industrial environments.
- EN61000-6-3:2001+A11:2004. Electromagnetic compatibility (EMC). Generic standards. Emission standard for residential, commercial and light industrial environments.
- BS 7273-4 category C. Code of practice for the operation of fire protection measures. Activation of release mechanisms for doors.
- USA patent number: 5525963
- European patent number: 0635092

Fireco reserves the right to alter specifications without prior notification.

Cost

£129.00+Carriage+VAT (RRP)

Carriage terms

*For all offshore and overseas destinations carriage available on request.
Goods are despatched on receipt of agreed payment method.
Please allow 5 to 10 working days for delivery (UK only). E & oe. See
terms and conditions at www.firecoltd.com/terms
or call 0845 241 7575*